

## Operating Instructions

Please read these instructions carefully before using the appliance!



### For your own safety

- Installation, commissioning and maintenance of this appliance may only be undertaken by an authorized professional who will then be responsible for adherence to the applicable standards and installation regulations.
- The appliance may only be used when correctly installed and in perfect working order!
- The appliance must be installed in a frost-free room!
- The appliance must be completely filled with water before being switched on!
- The appliance and its wiring and piping must not be modified in any way!
- The front cover of the appliance must never be opened before disconnecting the appliance from the mains power supply!
- Be careful! When the appliance has been in use for some time, the fittings may be very hot!
- The appliance must be earthed!

### Description of appliance

This appliance is a pressure-type, hydraulically controlled instantaneous water heater for decentral water heating at one or two taps situated in close proximity to one another. e.g. kitchen sink or wash basin.

Due to the integrated load-shedding circuit, this appliance can be connected to the outlet box of an electric cooker if a separate power supply is not available and provided that the cooker is connected to a 3/N/PE~380/400 V supply.

Technical specifications: → overleaf!

### Use

The instantaneous water heater heats the water as it flows through the appliance. The appliance only consumes power during this period. The heating power is switched on automatically in the event of the minimum flow rate being exceeded. The „Power“ light indicates that the heating system is switched on.

If the instantaneous water heater has been connected in combination with an electric cooker, the cooker will switch off while hot water is being withdrawn. Load shedding may only be used in conjunction with electromechanical cookers! Residual heat indicators are off while hot water is withdrawn!

The temperature of the hot water depends on the rate of flow and the temperature of the main water supply. By opening the tap more or less you can adjust the desired water temperature between approx. 40 °C and 60 °C:

**less flow = more hot • more flow = less hot**

If the heater supplies two outlets the water from the unit will be shared between the outlets. Therefore you should use only one outlet at the time to have a sufficient flow and to avoid variation in temperature.

### Temperature monitor

If the temperature rises too high, the temperature monitor will reduce the power supply until the water has cooled back to the permissible level. This is indicated by the „Overheat“ light. If the water overheats frequently, the cause of the fault must be remedied and may be due, for example, to dirt in the filter, an excessive reduction in the rate of flow or an impermissibly high inflow temperature.

### Venting

To prevent damage to the appliance, the instantaneous water heater must be vented before using it for the first time. Each time it is emptied (e.g. after work on the plumbing system, if there is a risk of frost or following repair work), the appliance must be re-vented before it is used again.

- 1 Disconnect appliance from the mains by removing the fuses.
- 2 Next, open and close the hot water tap valve several times until no more air emerges from the pipe and all air has been eliminated from the water heater (approx. 1 minute).
- 3 Only then should you re-connect the power supply to the unit.

### How to save energy in order to protect the environment

The heat lost via the water pipes is very low when installed directly alongside the pipes leading to the taps (open-outlet taps are recommended) and the hot water is rapidly supplied without drawing a great deal of cold water first.

### Maintenance and cleaning

- Plastic surfaces and fittings may only be wiped with a damp cloth. Never use abrasive cleaning agents or solvents.
- For a good water supply, the perlators and shower heads should be unscrewed and cleaned or renewed at regular intervals.
- The electrical and plumbing components should be inspected by an authorized professional at least every three years to ensure proper functioning and operational safety at all times.

### Cleaning the filter

In case of malfunctions, the filter within the cold water inlet should be inspected and cleaned if necessary.

### Troubleshooting

If you experience a malfunction, please try to rectify the fault yourself first with the help of this table. If a fault in your appliance cannot be rectified with the aid of this table, please contact CLAGE who will either assist you directly or put you in touch with a customer service contract partner in your area. Always specify the appliance model and serial number, please!

Repairs may only be carried out by authorized professionals.

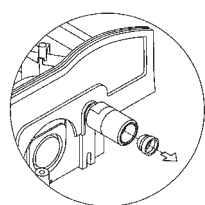
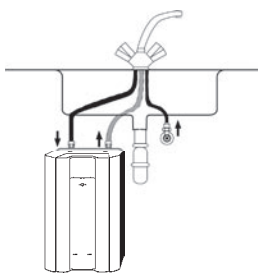

**CLAGE GmbH GERMANY**  
Customer Service  
Pirrolweg 1-5  
21337 Lueneburg  
Tel: +49 (0) 4131 8901-40  
Fax: +49 (0) 4131 8901-41  
E-Mail service@clage.de  
Internet www.clage.de

Problem	possible cause	Solution
The pilot lamp „Power“ does not light, water remains cold	Circuit breaker tripped	Have the fault rectified and reset
	Flow pressure switch is not working	Increase flow pressure
	Safety thermal cut-out tripped	Contact customer service
The pilot lamp „Power“ lights, water remains cold	Heating element is faulty	Replace the element by customer service
The pilot lamp „Overheat“ lights	Overtemperature	Increase flow, check cold water temp.
	Dirt in tap or filter	Cleaning, Customer service
Water flows lower as expected	Depends on the heater	Check technical specifications
	Outlet fitting dirty or calcified	Clean tap fitting or shower head
	Filter dirty or calcified	Clean or renew the filter
	Flow regulator with too low flow rate	Replace/remove flow regulator
	No suitable tap	Use CLAGE shower head or tap
The hot water is not hot enough	Flow rate is too high (winter?)	Reduce the water flow slightly Control/replace flow regulator
	Heating element defect	Contact customer service
Flow and temperature of the hot water varies	The water pressure or the voltage is varying	Stabilize flow pressure, check supply voltage

### Layout of appliance and spareparts

When ordering, please always specify the appliance model, nominal rating and serial number!

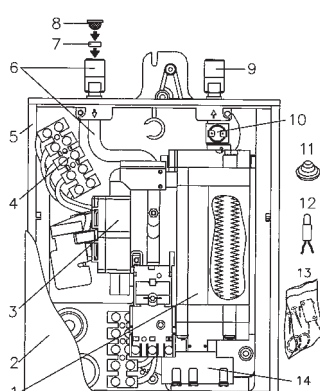

Pos.	Description
1	Heating element
2	Appliance front cover
3	Differential pressure switch
4	Connection terminal
5	Lower section of housing
6	Cold water inlet
7	Flow regulator
8	Filter
9	Hot water outlet
10	Temperature monitor
11	Cable seal
12	Pilot lamps
13	Set of small spareparts washers, filter, screws and microswitch (for spare requirements, not included in delivery)
14	Safety thermal cut-out (STB)

## Installation instructions for the authorized technician

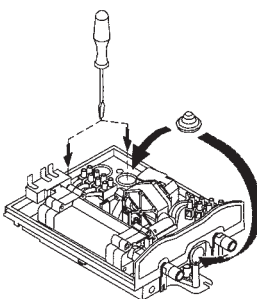
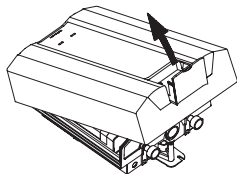
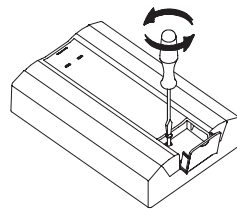

### The following must be observed:

- The statutory regulations of the respective country, as well as those of the local electricity and water supply companies.
- The specifications on the rating plate and the technical specifications.

### Installation site

- The installation site must be free from frost at all times.
- The appliance complies with protection type IP24 and may be installed in zone 1 acc. IEC, provided is not subjected to jets of water.
- In order to avoid thermal losses, the distance between the heater and the tapping point should be as small as possible (< 2 m).
- Best performance is guaranteed at a flow pressure of ≥ 3 bar, avoiding pressures exceeding 10 bar.
- The cooker load shedding may only be used when the cooker and fitting (tap) of the instantaneous water heater are installed in the same room (in sight of one another).

### Installing the appliance:

- 1 Rinse water supply pipes thoroughly and turn off for installation.
- 2 Remove the front cover by unscrewing the locking screw behind the small lid.
- 3 Locate and break out the required holes and cable inlets. Mark the drilling holes with the appliance and drill them with a 6 mm bit.
- 4 Fit the rubber grommet supplied and insert the connecting lead. The lead must be secured with the cable clamp when using a flexible power cord.
- 5 Screw the appliance into position using the enclosed dowels and screws.

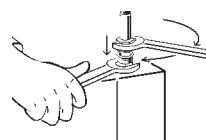
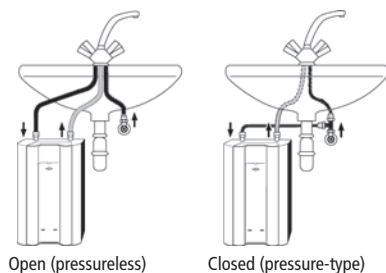

- 6 Install the appliance as shown in the principal examples above. The inlet and outlet are marked with arrows. Use Teflon tape or sealing washers when connecting via a 1/2" reducing nipple. Use a 13 mm spanner to prevent the connection pipes of the appliance from turning.
- 7 When connected directly to the connection pipes of the sanitary fitting, the front cover must be cleanly broken at the points indicated.
- 8 Open the water supply to the appliance and the tap to check all connections for leaks.
- 9 Next, open and close the hot water tapping valve several times until no more air emerges from the line and all air has been eliminated from the heater.

### Electrical connection:

**The instantaneous water heater is an appliance of protection class I and must be connected to the protective earth conductor!**

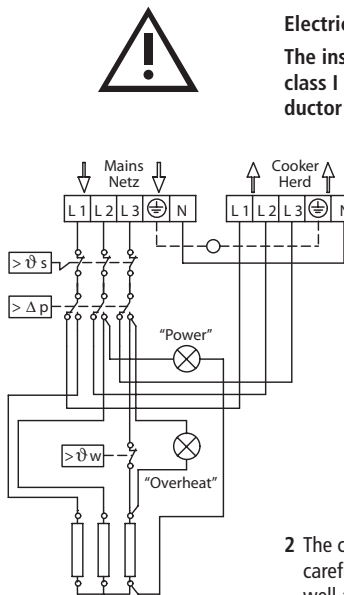

- 1 Check the power supply to be switched off prior to the electrical connection!

- The appliance must be connected to the supply by means of permanent wiring through suitable isolation having a contact separation of at least 3 mm in all poles.
- The cross sectional area of the connection cable must be in accordance to the power rating.
- To protect the appliance, a fuse element must be

fitted with a tripping current commensurate with the nominal current of the appliance.

- 2 The connection cable should be sealed with the cable seal and carefully connected to the terminal block using leads L1, L2, L3 as well as the earth conductor.

- The neutral conductor N may only be connected to terminal (A) when using the integrated priority circuit. The cooker cable must then be carefully connected to conductors L1, L2, L3, N and the protective earth conductor as indicated on the cooker connecting terminal (B). The cooker outlet box and cooker cable must be marked accordingly using the adhesive labels supplied.

- The connecting cable must not be subjected to tensile stress if the cable clamp is not used.

- 3 Mount the front cover and secure with the fixing screw.

- 4 Fill the appliance with water completely, switch on the power supply to the appliance.

- 5 Explain the use of the instantaneous water heater to the user and fold these instructions so that they can be stored behind the front panel.

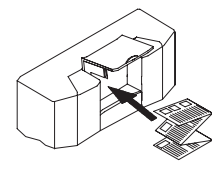
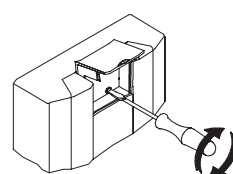
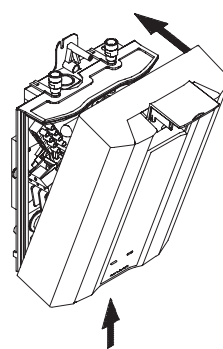
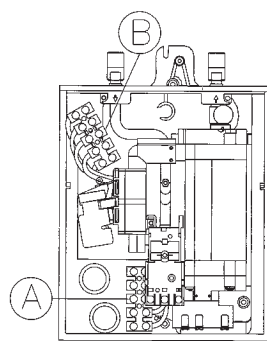

### Technical specifications

Type:	CBH 7	CBH 11
Capacity:	0.2 litre	
Type of system (rating pressure):	pressure type, 10 bar	
Heating system / Operative range	Bare element	
in waters of specific electric resistance:	≥ 900 Ω cm at 15°C	
Nominal rating at 400 V 3~:	6.9 kW	11 kW
Nominal loading:	10 A	16 A
Nominal loading of the cooker load shedding:	16 A	16 A
Required conductor cross-section:	4 x 1.5 mm <sup>2</sup> - For cooker connection: 5 x 2.5 mm <sup>2</sup> - 4 x 2.5 mm <sup>2</sup>	
Switch-on point @ Pressure loss:	2.6 l/min @ 0.5 bar	3.5 l/min @ 0.7 bar
Switch-off point @ Pressure loss:	2.2 l/min @ 0.3 bar	3.0 l/min @ 0.5 bar
Factory-mounted flow regulator:	4 l/min	5 l/min
Temperature rise Δt:	25 K	31 K
Hot water temperature at cold water inlet temp. of 15°C:	40 °C	46 °C
Maximum hot water temperature:	60 °C	60 °C
Useful for cold water of approx.:	15 °C	15 °C
Water connection:	3/8" B.S.P. top	3/8" B.S.P.
Weight:	1.8 kg	
Dimensions (H x W x D):	33 x 21 x 9 cm	
Class / Degree of protection (IEC 529):	I / IP24	
Approvals:	see rating plate	